

Back Glass Saver Assembly Instructions

PART LIST

- A. Stand-off bracket
- B. Arm bracket
- C. Black Metal Bar
- D. End Cap
- E. 3/8-16x4" Hex head bolt
- F. 10/24 x 1.25 Phillips Pan Head Screw
- G. 3/8 Wing Nut
- H. 3/8 Split Lock Washer
- I. 10/24 Wing Nut
- J. 3/16 Flat Washer
- K. 5x9/16x3/4 Snap Spacer
- L. 1.5x9/16x3/4 Snap Spacer

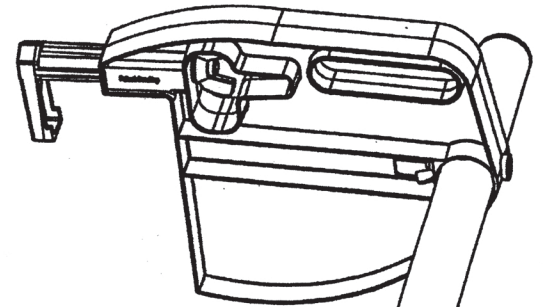

Assembly Instructions

- 1) Slide Arm Bracket (B) into rectangular hole of Bracket (A) Install Bolt (E) into Hole in bracket (B).
- 2) Slip washer (H) over end of (E) attach 3/8 wing nut to (G) to end of bolt (E) leave loose for adjustment
- 3) Slip metal bar in round hole of bracket (A) align holes in metal bar (C) with holes in bracket (A)
- 4) Install 10/24 screw (F) through holes in bracket (A) and metal bar (C)
- 5) Install washer (J) on end of screw (F) attach 10/24 wing nut (I) tighten wing nut as tight as possible
- 6) Repeat steps 1-5 for opposite end of Back Glass Saver
- 7) Position in center of truck bed behind back window and tighten 3/8 wing nuts (G) until Back Glass Saver is secure to truckbed.
- 8) If needed snap the smaller (K) snap spacer at the very top back portion of the CargoBar Standoff Bracket(A)
- 9) If needed snap the larger (L) snap spacer at the bottom of the back portion of the Back Glass Saver Standoff Bracket
- 10) Most all trucks only need spacer(L) at the bottom of the Standoff Bracket(A)
- 11) The spacer is only to fill the gap at the bottom of the Standoff Bracket(A) between the truck bed and the bracket
- 12) 07 and newer Chevys do not need either bracket

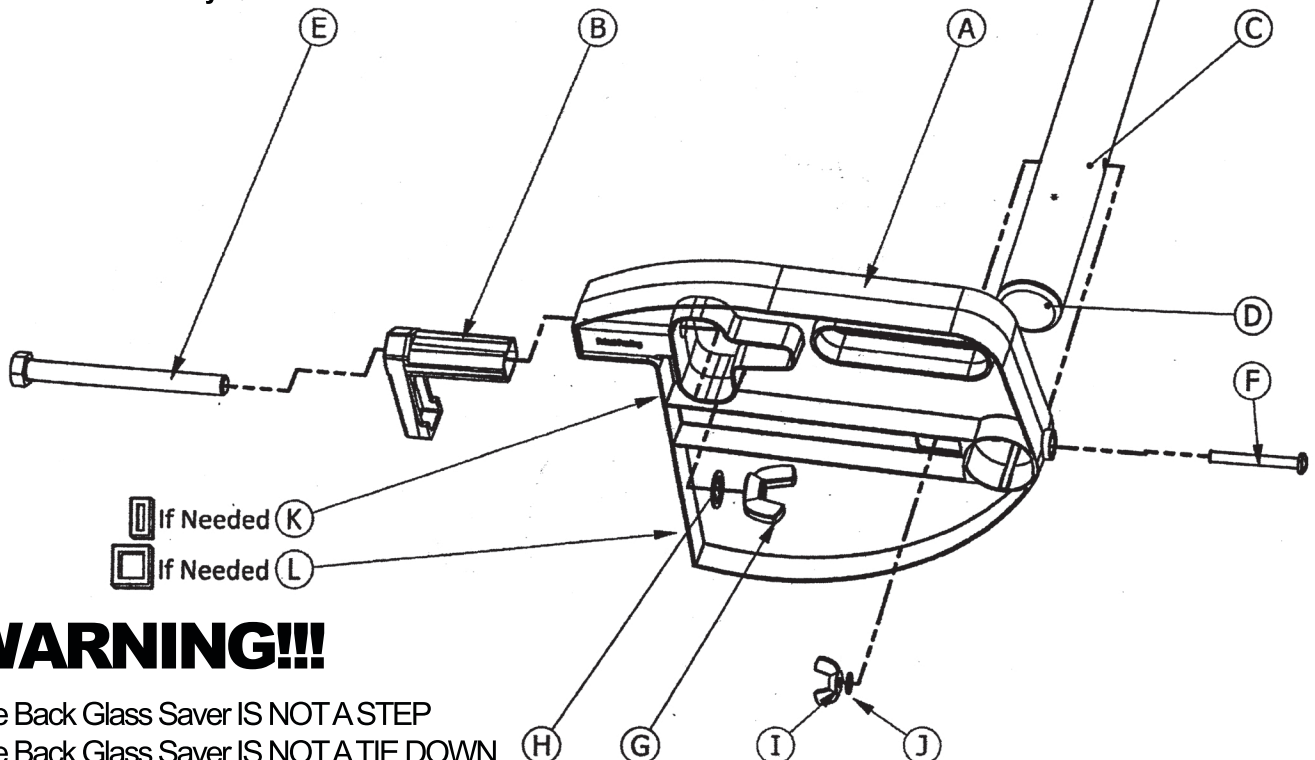

WARNING!!!

The Back Glass Saver IS NOT A STEP

The Back Glass Saver IS NOT A TIE DOWN

Assembly pack has small parts that may cause choking keep out of reach of children.

No Wenching, using the Back Glass Saver for anything but a cargo stopper may result in personal injury or vehicle damage.